

Job:  
 Type:  
 Notes:

# Poles

## Tapered Round Aluminum - Cast Base

The Philips Gardco TRA tapered round aluminum pole consists of a one-piece design fabricated aluminum tubing circumferentially welded to a structural quality hot rolled carbon steel plate. The poles are finished with either Architectural Class I anodizing or electrostatically applied TGIC polyester powdercoat. All poles include anchor bolts, hand hole, ground lug and top cap.

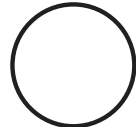

Enter the order code into the appropriate box above. Note: Gardco reserves the right to refuse a configuration. Not all combinations and configurations are valid. Refer to notes below for exclusions and limitations. For questions or concerns, please consult the factory.

PREFIX	BASE	HEIGHT	DRILLING
TRA	CB Fixed Cast Base	8' 10' 12' L,M' 14' L,M' 16' L,H' 20' M,H'	25' L,H' 28' L,H' 30' L,H' 35' L,H' 39' L,H'
		1. Refers to relative strength based on wind load factors. L=Light; M = Medium; H = Heavy.	

FINISH	
BRP	Bronze Paint
BLP	Black Paint
WP	White Paint
NP	Natural Aluminum Paint
BRA	Bronze Anodized
BLA	Black Anodized
NA	Natural Anodized
OC	Optional Color Paint Specify Optional Color or RAL ex: OC-LGP or OC-RAL7024.
SC	Special Color Paint Specify. Must supply color chip.

OPTIONS	
DR	Duplex Receptacle
GFCI	Ground Fault Receptacle
VDA	Vibration Dampener
<b>Nipples and Couplings</b>	
Indicate size (1/2", 3/4", 1", 1 1/4", 1 1/2".) Indicate height above base and orientation to hand hole. See Pole Orientation Information on Page 4.	
NL	Nipple - External thread
CL	Coupling - Internal thread
<b>Single Mount Bullhorn Brackets</b>	
Indicate height above base and orientation to hand hole. See Pole Orientation Information on Page 4.	
A15BH-19	Single - 1.9" OD
A15BH-24	Single - 2.4" OD
A215BH-19	2-Tenon - 1.9" OD
A215BH-24	2-Tenon - 2.4" OD
<b>Motion Response Provisions</b>	
GMR	Provision for Gardco HID Motion Response System
Minimum Pole Height is 18'. Includes a 1/2" coupling placed 180° to the hand hole, 12' above the pole base.	
MSM	Motion Sensor Mounting Provision for LED Luminaires available with Motion Response
Minimum Pole Height is 18'. Includes a special hand hole with 1/2" coupling placed in the cover plate, 180° to the hand hole, 15' above the pole base.	



### POLE DATA

CATALOG NUMBER	POLE SIZE			MAXIMUM LUMINAIRE LOADING <sup>2</sup>			ANCHOR BOLT DATA <sup>3</sup>	
	PREFIX - BASE - HEIGHT	ACTUAL HEIGHT	POLE SHAFT SIZE (Top" x Base")	WALL THICKNESS (inches.)	100 MPH EPA-FT <sup>2</sup>	90 MPH EPA-FT <sup>2</sup>	80 MPH EPA-FT <sup>2</sup>	BOLT CIRCLE (inches)
TRA-CB-8	7' 8"	3 x 4	.125	8.6	10.9	14.2	6.50 - 8.25	3/4 x 17 x 3
TRA-CB-10	9' 8"	3 x 4	.125	6.1	7.9	10.4	6.50 - 8.25	3/4 x 17 x 3
TRA-CB-12L	11' 8"	3 x 4	.125	4.2	5.6	7.8	6.50 - 8.25	3/4 x 17 x 3
TRA-CB-12M	11' 8"	3 x 5	.125	8.0	10.2	13.4	7.50 - 9.50	3/4 x 17 x 3
TRA-CB-14L	13' 8"	3 x 4	.125	2.8	4.0	5.8	6.50 - 8.25	3/4 x 17 x 3
TRA-CB-14M	13' 8"	3 x 5	.125	6.0	7.8	10.5	7.50 - 9.50	3/4 x 17 x 3
TRA-CB-16L	15' 8"	3 x 5	.125	4.5	5.9	8.1	7.50 - 9.50	3/4 x 17 x 3
TRA-CB-16M	15' 8"	3 x 5	.188	7.5	9.8	12.9	7.50 - 9.50	3/4 x 17 x 3
TRA-CB-20M	19' 8"	3 x 5	.156	3.2	4.6	6.6	7.50 - 9.50	3/4 x 17 x 3
TRA-CB-20H	19' 8"	3 x 5	.188	4.5	6.1	8.7	7.50 - 9.50	3/4 x 17 x 3
TRA-CB-25L <sup>4</sup>	24' 8"	4 x 6	.156	3.1	4.2	6.2	8.75 - 10.25	3/4 x 17 x 3
TRA-CB-25H	24' 8"	4 x 7	.156	6.4	8.2	11.2	9.88 - 11.25	1 x 36 x 4.5
TRA-CB-28L <sup>4</sup>	27' 8"	4 x 7	.156	4.2	5.8	8.1	9.88 - 11.25	1 x 36 x 4.5
TRA-CB-28H	27' 8"	4.5 x 8	.188	10.1	12.9	16.9	11.0 - 12.13	1 x 36 x 4.5
TRA-CB-30L <sup>4</sup>	29' 8"	4 x 7	.156	3.2	4.5	6.5	9.88 - 11.25	1 x 36 x 4.5
TRA-CB-30H	29' 8"	4.5 x 8	.188	8.6	11.1	14.6	11.0 - 12.13	1 x 36 x 4.5
TRA-CB-35L <sup>4</sup>	34' 8"	4.5 x 8	.156	3.4	4.8	6.8	11.0 - 12.13	1 x 36 x 4.5
TRA-CB-35H	34' 8"	4.5 x 8	.250	8.8	11.4	15.2	11.0 - 12.13	1 x 36 x 4.5
TRA-CB-39L <sup>4</sup>	38' 8"	4.5 x 8	.188	3.2	4.6	6.6	11.0 - 12.13	1 x 36 x 4.5
TRA-CB-39H	38' 8"	6 x 10	.188	9.2	12.4	16.7	14.50	1 x 36 x 4.5

2. **Warning:** Additional wind loading, in terms of EPA, from banners, cameras, floodlights and other accessories attached to the pole, must be added to the luminaire(s) EPA before selecting the pole with the appropriate wind load capability.

3. Factory supplied template must be used when setting anchor bolts. Philips Gardco will not honor any claim for incorrect anchorage placement resulting from failure to use factory supplied templates.

4. Includes (VDA) Vibration Dampener standard.

### DIMENSIONS

**NOTE:** Factory supplied template must be used when setting anchor bolts. Philips Gardco will not honor any claim for incorrect anchorage placement from failure to use factory supplied templates.

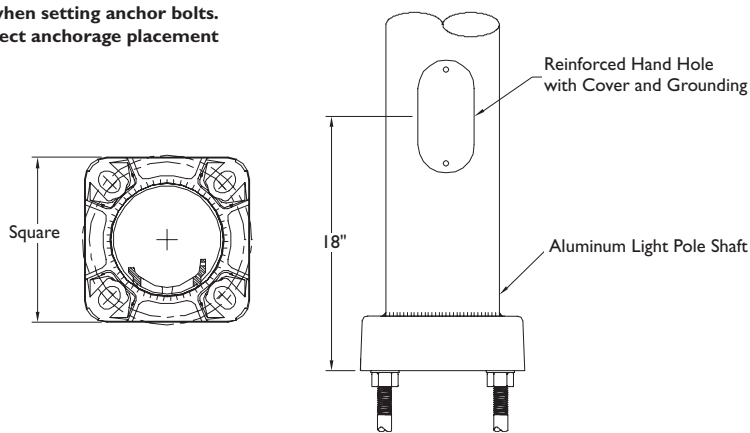

1611 Clovis Barker Road, San Marcos, TX 78666

(800) 227-0758 (512) 753-1000 FAX: (512) 753-7855 [sitelighting.com](http://sitelighting.com)

© 2011 Koninklijke Philips Electronics N.V. All Rights Reserved.

Philips Gardco reserves the right to change materials or modify the design of its product without notification as part of the company's continuing product improvement program.

79415-24/0611

**PHILIPS**



## SPECIFICATIONS

All aluminum alloys shall comply with metalurgical and mechanical properties set forth in the Aluminum Association Standards.

**POLE SHAFT:** The pole shaft shall be spun tapered from all new seamless 6063 alloy aluminum and shall be heat treated to produce a T6 temper. Each shaft shall have a minimum 6" long straight section at the top to accommodate drilling and/or Philips Gardco floodlight and bullhorn brackets. Shafts are polished with fine grain aluminum oxide cloths, resulting in a high quality, circumferential satin brushed finish. After finishing, each pole shall be fully wrapped with neutral PH krinkle/kraft paper for protection in shipment.

**ANCHOR BASE:** The anchor base (base plate) is cast from A356 alloy aluminum. The anchor base casting and shaft shall be joined by a continuous circumferential weld at the inside bottom of the anchor base. The completed assembly will be heat treated to T6 temper after all structural welding is completed. The 1100-0 alloy collars are spun from heavy duty .125" stock, making them damage and vandal resistant.

**ANCHOR BOLTS:** Anchor bolts are fabricated from a commercial quality hot rolled carbon steel bar with a minimum yield strength of 55,000 PSI. Bolts have an "L" bend on one end and threaded on the opposite end. Anchor bolts are hot dipped galvanized a minimum length of 12" on the threaded end. Four (4) properly sized bolts, each furnished with two (2) hex nuts and flat washers, are provided per pole, unless otherwise specified.

**HAND HOLE:** All poles include a peripherally reinforced flush covered hand hole centered 18" above the bottom of the pole. The opening in the 4" diameter pole shall measure 2 3/8" X 4 1/2". The opening in the 5" and 6" diameter pole shall measure 3" X 5". The opening in the 7", 8" and 10" diameter pole shall measure 4" X 6".

**FINISH:** Poles are available with bronze, natural or black Aluminum Association Architectural Class I anodized finish. Electrostatically applied, thermally cured TGIC polyester powdercoat finish or liquid polyurethane is also available.

## GENERAL POLE INFORMATION

**DESIGN:** The poles as charted are designed to withstand dead loads and predicted dynamic loads developed by variable wind speeds with an additional 30% gust factor under the following conditions:

The charted weights include luminaire(s) and/or mounting bracket(s).

The wind velocities are based on 10 mph increments from 80 mph through 100 mph. Poles to be located in areas of known abnormal conditions may require special consideration. For example: coastal areas, airports and areas of special winds.

Poles are designed for ground mounted applications. Poles mounted on structures (such as buildings and bridges) may also necessitate special consideration requiring Philips Gardco's recommendation.

Height correction factors and drag coefficients are applied to the entire structure. An appropriate safety factor is maintained based on the minimum yield strength of the material incorporated in the pole.

**WARNING:** This design information is intended as a general guideline only. The customer is solely responsible for proper selection of pole, luminaire, accessory and foundation under the given site conditions and intended usage. The addition of any items to the pole, in addition to the luminaire, will dramatically impact the EPA load on that pole. It is strongly recommended that a qualified professional be consulted to analyze the loads given the user's specific needs to ensure proper selection of the pole, luminaire, accessories, and foundation. Philips Gardco assumes no responsibility for such proper analysis or product selections. **Failure to insure proper site analysis, pole selection, loads and installation can result in pole failure, leading to serious injury or property damage.**

**GENERAL INFORMATION:** Mounting height is the vertical distance from the base of the lighting pole to the center of the luminaire arm at the point of luminaire attachment. Twin arms as charted are oriented at 180° with respect to each other. For applications of two (2) arms at 90° or other multiple arm applications, consult the factory.

**WARRANTY:** Philips Gardco poles feature a 1 year limited warranty. See Warranty Information on [www.sitelighting.com](http://www.sitelighting.com) for complete details and exclusions.

### ORIENTATION INFORMATION

#### FACTORY INSTALLED OPTIONS AND ACCESSORIES

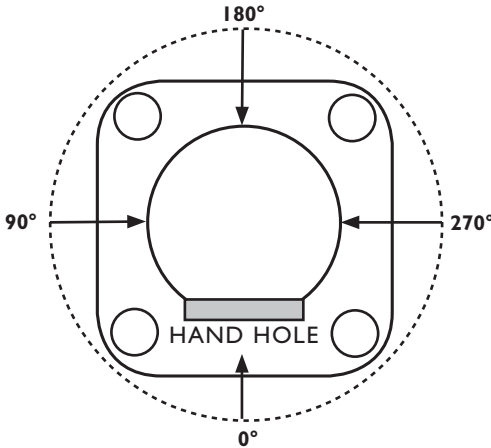

Orientation is measured clockwise from the Hand Hole Center.

For Factory Installed Options and Accessories, Specify Orientation from Hand Hole and Height Above Pole Base Where Required.

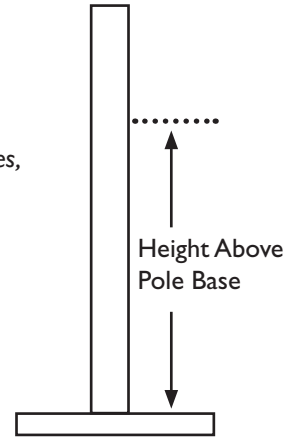

#### STANDARD ARM MOUNT LUMINAIRE ORIENTATION

**D1** Drilled for Single Luminaire

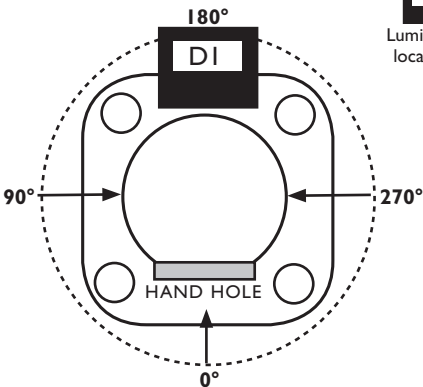

**D2** Drilled for 2 Luminaires at 180°

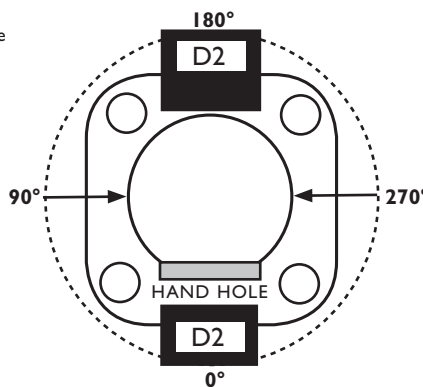

**D3** Drilled for 3 Luminaires @ 90°

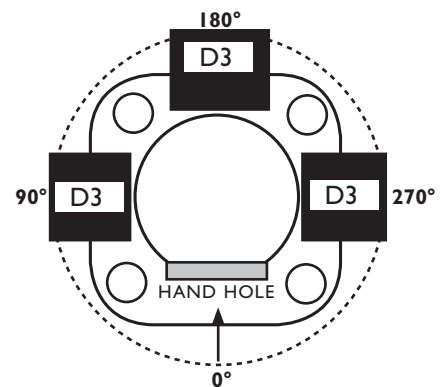

**D4** Drilled for 4 Luminaires at 90°

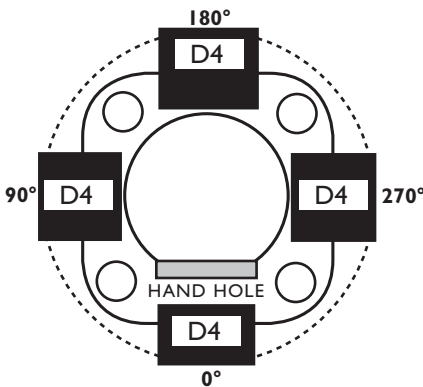

**D2@90** Drilled for 2 Luminaires at 90°

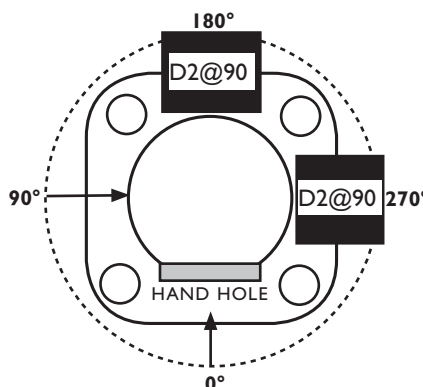

**D3@120** Drilled for 3 Luminaires at 120°

