

INSTALLATION INSTRUCTIONS



EMCO LIGHTING
1611 Clovis Barker Road
San Marcos, TX 78666
www.sitelighting.com

A4055001 REV A

SHEET 1 OF 3

© COPYRIGHT 2008 EMCO LIGHTING

AVALUME FLUORESCENT LUMINAIRE TO ROUND/SQUARE POLE

**IMPORTANT: READ ALL INSTRUCTIONS BEFORE PERFORMING ANY WORK.
BE SURE ALL POWER IS OFF PRIOR TO INSTALLING LUMINAIRES.**

1. Insert the bolster plate into the inside of pole with tapped hole toward the base. Install lockwasher and 1.00" flat washer to the 3/8-16 x 2 1/4" hex head bolt and bolt through the top mounting hole. Install split lockwasher and nut to the end of the top bolt. **See Fig. 1.**

NOTES: if round pole is 3.10" to 3.70" O.D. use the Round Pole Adapter (**RPA1**) and place it between pole and luminaire as shown. **See Fig. 2.**

Square Poles: Attach Gasket to square pole. **See Fig. 3.**

2. Hook luminaire over the top bolt and hand tighten.

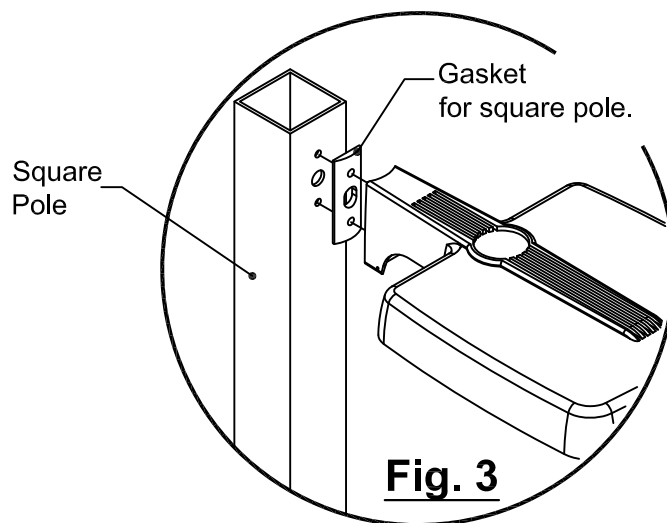
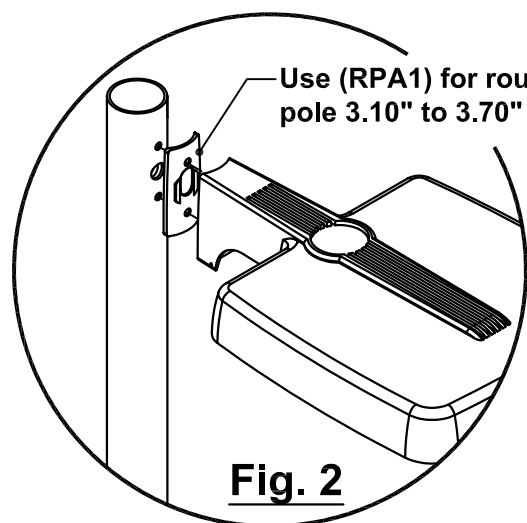
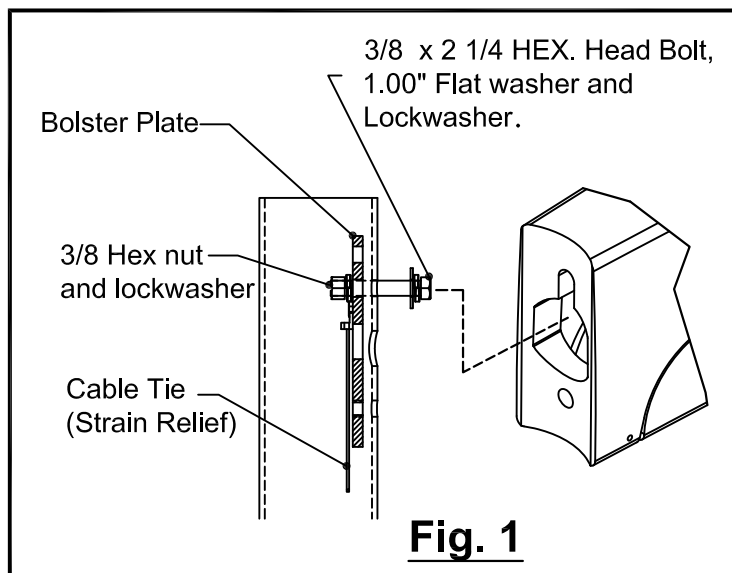

3. Loosen (2) # 1/4-20 socket head cap screws using 3/16 allen wrench and open door assembly. **See Fig. 4.**
4. Thread 3/8-16 x 1 3/4" hex head bolt with lockwasher into the bottom tapped hole in the bolster plate. **Tighten bolts to 18 ft-lbs.**
5. Connect supply and ground wires to Luminaire Leads. **Make wire connections per NEC or applicable local codes.**
6. Secure the supply and ground wires with the cable tie (strain relief)
7. Install proper lamps (by others) per luminaire markings.
8. Install photocontrol if used. **See Fig. 5.**
9. Close door and secure it being careful not to over tighten the bolts.

INSTALLATION INSTRUCTIONS



EMCO LIGHTING
1611 Clovis Barker Road
San Marcos, TX 78666
www.sitelighting.com

A4055001 REV A

SHEET 2 OF 3

© COPYRIGHT 2008 EMCO LIGHTING

AVALUME FLUORESCENT LUMINAIRE TO ROUND/SQUARE POLE

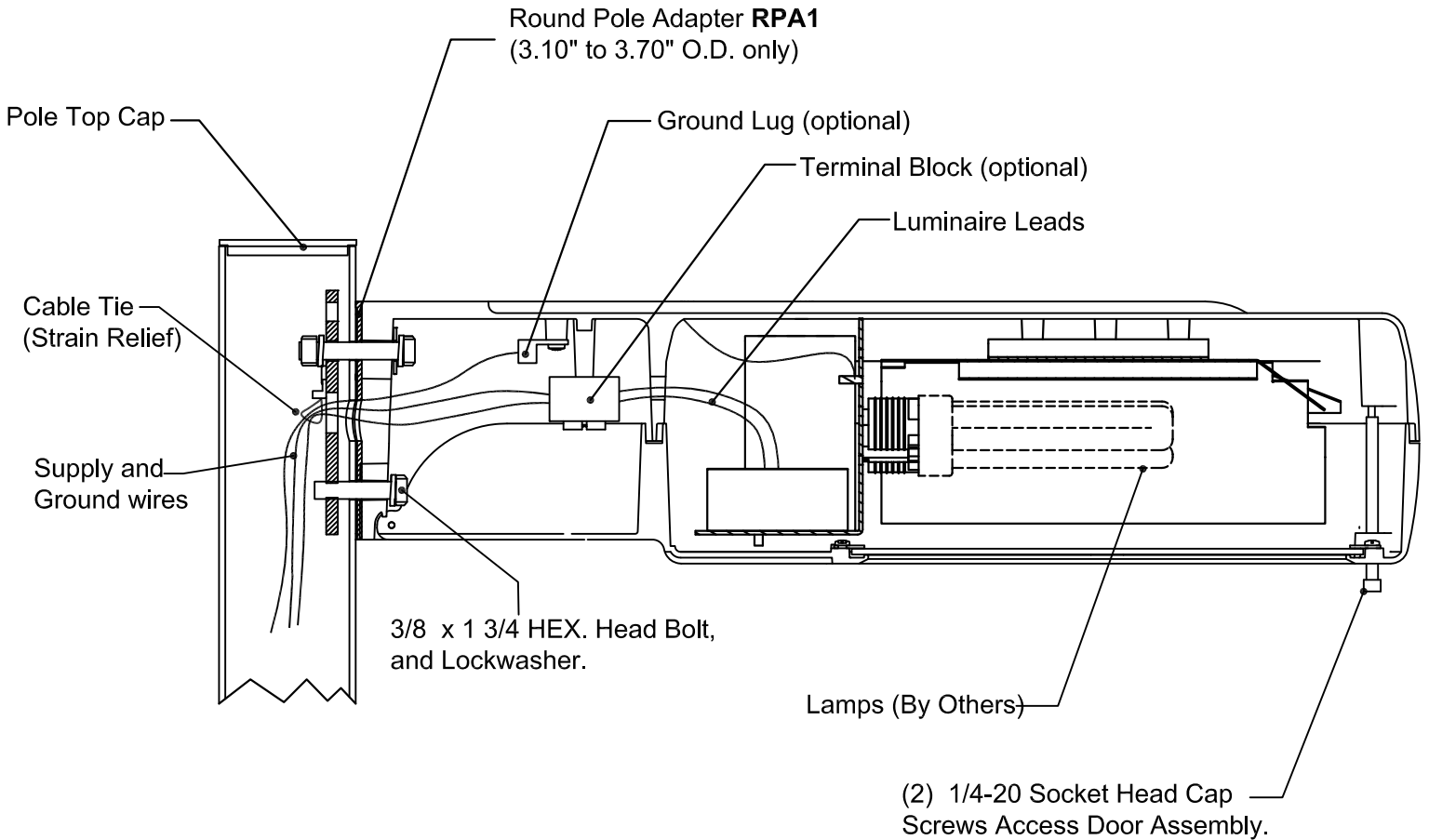

Fig. 4

INSTALLATION INSTRUCTIONS



EMCO LIGHTING
1611 Clovis Barker Road
San Marcos, TX 78666
www.sitelighting.com

A4055001 REV A

SHEET 3 OF 3

© COPYRIGHT 2008 EMCO LIGHTING

AVALUME FLUORESCENT WITH OPTIONAL PHOTOCONTROL (PC)

1. Loosen the (2) # 6-32 Flathead Screws.
2. Aim "North" arrow on the Photocontrol Receptacle (PCR) as desired.
3. Tighten the flathead screws.
4. Install the Photocontrol.

